



**NX10 • NX12**  
**DUAL VOICE COIL SUBWOOFERS**  
Installation Instructions / Owner's Manual



## ***INTRODUCTION***

Congratulations on your purchase of a NXS subwoofer. Your selection of a NXS Mobile Audio product indicates a true appreciation of fine musical reproduction. Whether adding to an existing system or including a NXS subwoofer in a new system, you are certain to notice immediate performance benefits.

## ***RECOMMENDATION***

A speaker's performance is only as good as it's enclosure. Proper installation, enclosure size and crossover frequency will maximize the overall performance of the subwoofer. To properly design and build an enclosure, knowledge of woodworking as well as the proper tools are required. We highly recommend that you have your enclosure built by an authorized NXS retailer. However, if you decide to install it yourself, we have included the parameters of each driver and recommended enclosure sizes. For up to date product and technical information, please visit our website at [www.nxsmobileaudio.com](http://www.nxsmobileaudio.com).

### **WARNING!**

**Exposure to high sound pressure levels can cause hearing loss or damage. Listening to your system at loud levels while driving, will impair your ability to hear traffic sounds and emergency vehicles. Use common sense when listening to your system.**

**When installing your subwoofer enclosure in the vehicle, securely fasten it to the frame or floorpan. If the enclosure is not secured properly, there is danger of it becoming a projectile in a collision.**

Due to continuing product improvement, specifications and design are subject to change without notice.

# PRODUCT SPECIFICATIONS *(Voice Coils in Series)*

		<b>NX10</b>	<b>NX12</b>
Free Air Resonance.	(FS)	30	27
Total Q of driver @ FS including all resistances.	(Qts)	.51	.55
Q of driver @ FS including non electrical resistance.	(Qms)	3.66	3.97
Q of driver @ FS including electrical resistance.	(Qes)	.59	.64
The driver's compliance expressed as an equivalent volume of air (Liters).	(Vas)	51	79.84
The driver's linear displacement (millimeters).	(Xmax)	10	10
The DC resistance of the driver's voice coil (ohms).	(Re)	6.5	6.7
Thermal power rating of driver (R.M.S./Peak).	(Pe)	250/500	250/500
The driver's voice coil inductance (millihenries).	(Le)	3.1	3.1
The drivers sensitivity (dB).	(Sens)	87	89

## CALCULATING ENCLOSURES

It is difficult to give exact box dimensions that are universal for all cars and trucks. It is for this reason that you must be able to calculate the space in which you have available in order to achieve the proper air volume required.

It is recommended to build your enclosure from 3/4" thick MDF (medium density fiberboard). Make sure the enclosure is sealed airtight.

### Calculating External Volume

- 1.) To calculate box volume, measure the outside Width x Height x Depth of the enclosure. *Example 12" x 14" x 9" = 1512".*
- 2.) Next you must convert cubic inches into cubic feet. To do this, you must divide the cubic inch total by 1728". *Example 1512 ÷ 1728 = .875 Cubic feet*

### Calculating Internal Volume

- 1.) To calculate the internal (net) volume of the above box you must first multiply the thickness of the wood you are using by Two (2). *Example 3/4" x 2 = 1.5".*
- 2.) Next subtract 1.5 from each of the outside measurements of the box.

$$\begin{array}{l} \text{Width} \\ 12-1.5=\mathbf{10.5} \end{array}$$

$$\begin{array}{l} \text{Height} \\ 14-1.5=\mathbf{12.5} \end{array}$$

$$\begin{array}{l} \text{Depth} \\ 9-1.5=\mathbf{7.5} \end{array}$$

- 3.) Multiply the new totals (H x W x D) *Example: 10.5 x 12.5 x 7.5 = 984.375*
- 4.) Next you must convert cubic inches into cubic feet. To do this, you must divide the cubic inch total by 1728" *Example 984.375 ÷ 1728 = .5696 cubic feet.*

# RECOMMENDED ENCLOSURES (NX10)

Please Note: Our suggested box volumes are given as internal air requirements

## Sealed Enclosure

Box Volume \* .62 Cu Ft. (17.76 Liters)

\* Box is given as internal air volume including driver displacement.

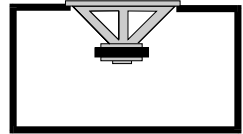

**NX10 Amplitude Response (dB/Hz)**

*Sealed Enclosure*

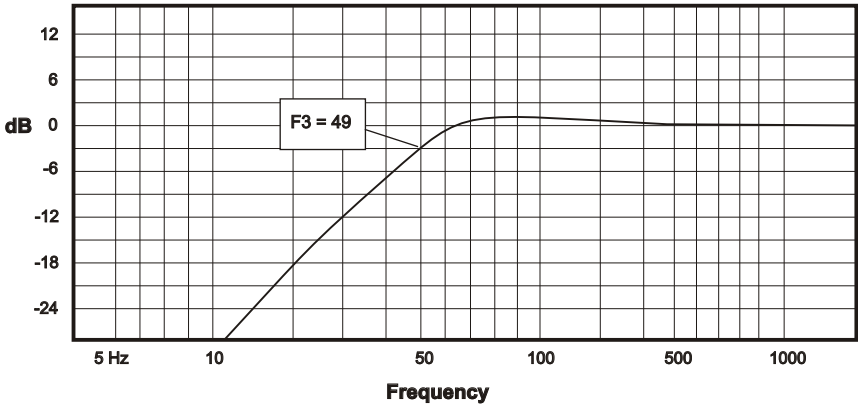

## Ported Enclosure

Box Volume \* 1.4 Cu Ft. (39.63 Liters)

Port Frequency (Fb) 35 Hz (35 Hz)

Port Diameter 3 Inches (76.2 mm)

Port Length 10.25 Inches (260.2 mm)

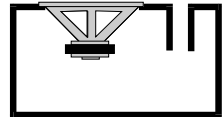

\* Box is given as internal air volume including port and driver displacement.

**NX10 Amplitude Response (dB/Hz)**

*Ported Enclosure*

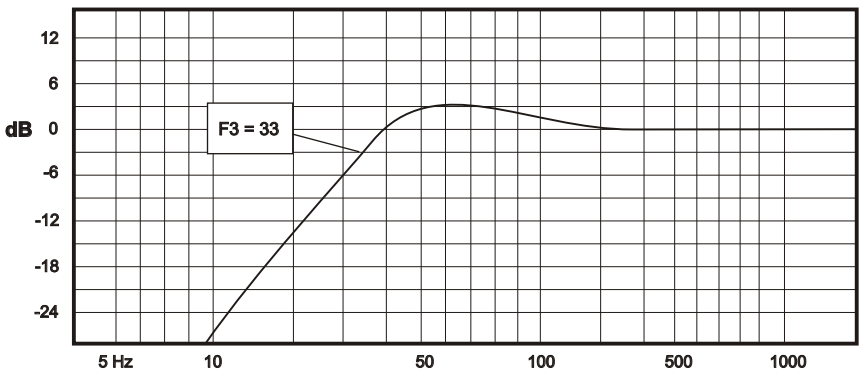

# RECOMMENDED ENCLOSURES (NX12)

Please Note: Our suggested box volumes are given as internal air requirements

## Sealed Enclosure

Box Volume \* 1.0 Cu Ft. (28.35 Liters)

\* Box is given as internal air volume including driver displacement.

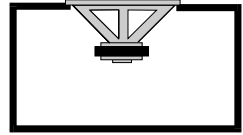

**NX12 Amplitude Response (dB/Hz)**

*Sealed Enclosure*

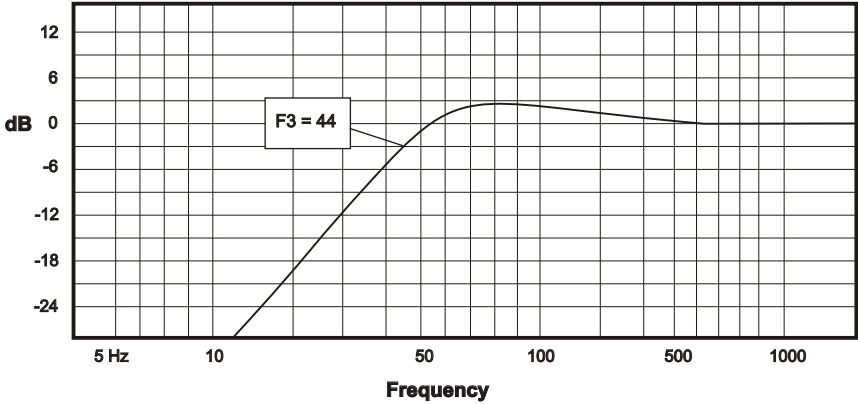

## Ported Enclosure

Box Volume \* 2.0 Cu Ft. (55.93 Liters)

Port Frequency (Fb) 35 Hz (35 Hz)

Port Diameter 4 Inches (101.6 mm)

Port Length 12.8 Inches (325.15 mm)

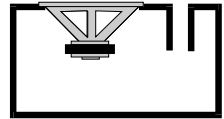

\* Box is given as internal air volume including port and driver displacement.

**NX12 Amplitude Response (dB/Hz)**

*Ported Enclosure*

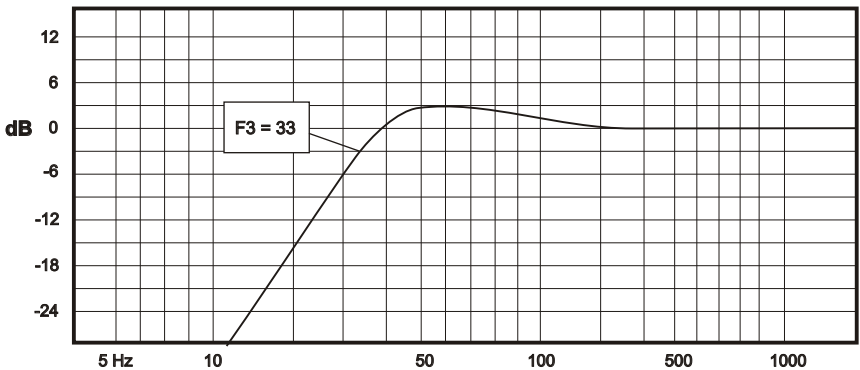

# NX10 & NX12 WIRING CONFIGURATIONS

**Parallel Connections  
Dual 4 Ohm Voice Coil Subwoofer**

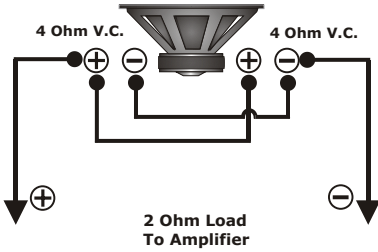

**Series Connections  
Dual 4 Ohm Voice Coil Subwoofer**

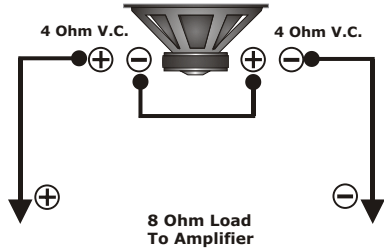

**Parallel Connections  
Dual 4 Ohm Voice Coil Subwoofers**

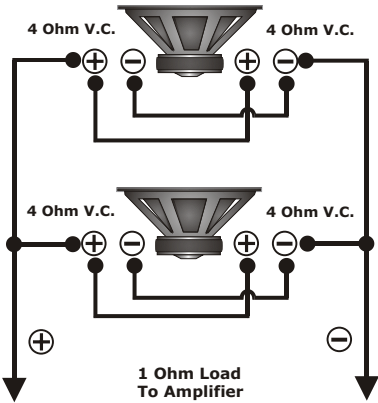

**Combination Series/Parallel Connections  
Dual 4 Ohm Voice Coil Subwoofers**

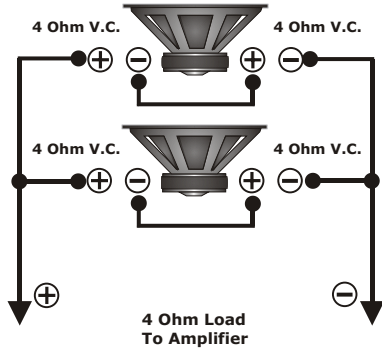

## NX10 DIMENSIONS

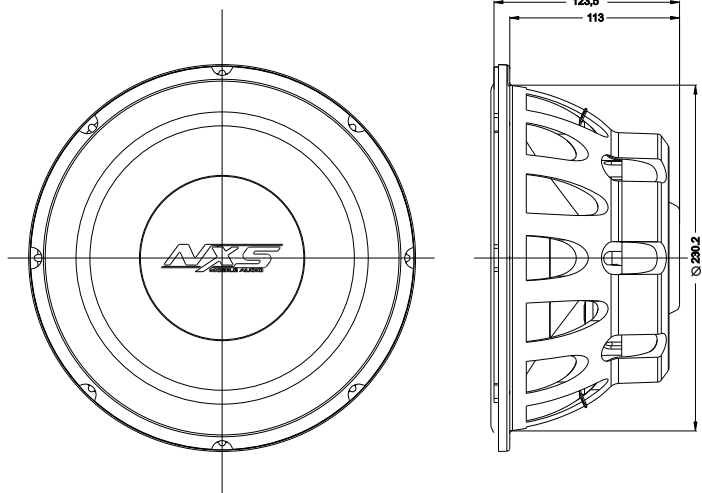

## NX12 DIMENSIONS

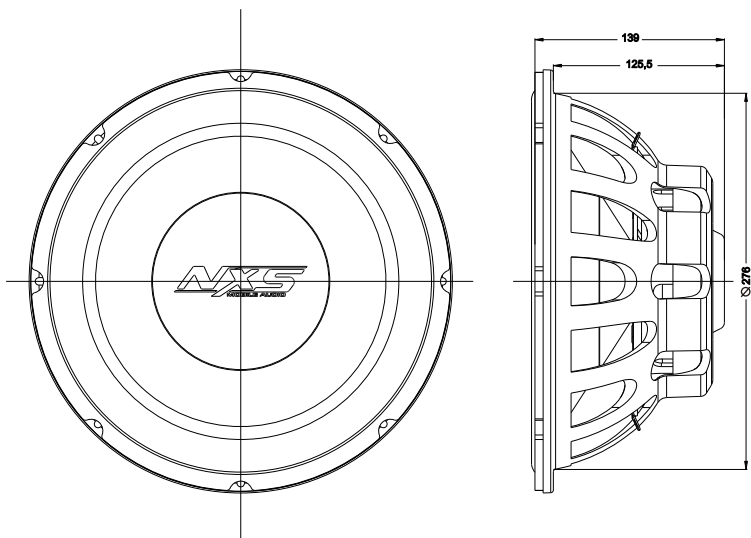

# TAKE CONTROL



[www.nxsmobileaudio.com](http://www.nxsmobileaudio.com)